



Photo Electric Smoke Detector Head

FW511



DESCRIPTION

The FW511 is an intelligent Smoke Detector used with the FW500/FW501 Detector Base, is a UL/ULC listed device according to UL 268 and ULC-S529 for Fire Protective Signaling Systems for indoor use and FM. It features a slim design that combines visual appeal with a high standard of reliability. It responds quickly and dependably to a broad range of fires. The detector has a Microcontroller Unit (MCU), performing comprehensive self-diagnostic tests and result analysis. The FW511 is intelligent, addressable, and takes one address on the Signaling Line Circuit (SLC) of the fire alarm control panel.

ATTENTION

Products must be installed per the National Fire Alarm Code, NFPA 72, CAN / ULC-S524, and/or National Electrical Code, depending on the country of the installation. Check the information on equipment used in the system from other manufacturers for instructions and restrictions. The detector should never be installed in the following places: where there is a lot of exhaust gas, kitchens, near fireplaces, boilers, etc. Smoke detectors should not be used with detector guards unless the suit has been evaluated and approved for this case.

NOTE

Do not paint this unit.

Any material extrapolated from this document or Maple Armor's instructions or other materials describing the product for promotional or advertising purposes, or any other purpose, including the description of the application, the use, installation, and testing of the product is the sole responsibility of the user. Maple Armor assumes no responsibility for the use. In no event shall Maple Armor's liability exceed the purchase price of the product.

INSTALLATION

Mount the FW500 base onto a 2x4" electrical box, see Figure 1. The installation hole pitch illustrated

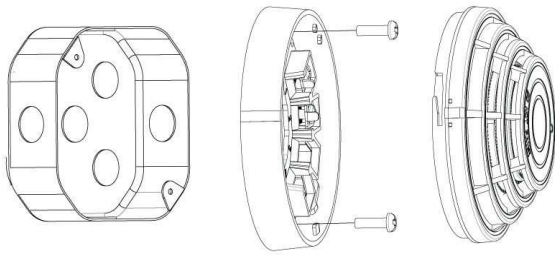

Smoke detector bases FW500/501 can be used with 12 AWG to 18 AWG.

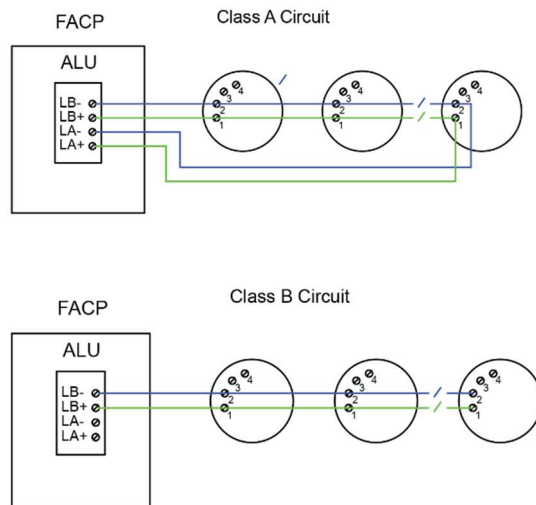
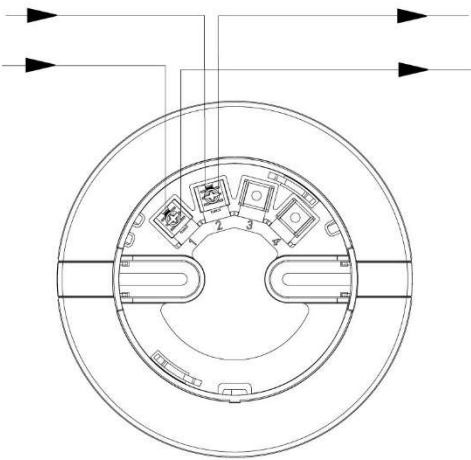

SPECIFICATION

FW511	
Nominal Voltage	24 VDC
Voltage Range	15 to 28 VDC
Standby Current	0.14 mA
Alarm Current	1 mA
Smoke Sensitivity	1.6% / ft to 2.3%/ ft
Operating Temperature	32°F to 100°F (0°C to 38°C)
Operating Humidity	0% to 93% RH
Diameter	4.13 in. (105mm)
Height (with base)	1.87 in. (47.5mm)
Weight (with base)	4.6 oz (132g)
Mounting	FW500/FW501 Base
Mounting Orientation	Ceiling, wall
Spacing	30 feet (9.1 M)

CATALOG NUMBER TO ORDER

Model	Description
FW511	Photoelectric smoke detector
FW500	Smoke detector base 4,13 in. (105mm)
FW501	Smoke detector base 5,91 in. (150mm)
STI-8100	Cover Non-ULC for smoke detector
STI-8130	Lexan Surface cover for smoke detector
STI-9601	Wire guard white low profile
STI-9604	Wire guard white
STI-9706	Wire guard white