



Heat Detector Head

FW521



DESCRIPTION

The FW521 is an intelligent Heat Detector with both fixed-temperature alarm and rate-of-rise alarm characters (Temperature 135° F/57° C) is a UL/ULC listed device according to UL 521 and ULC-S530 for Fire Protective Signaling Systems for indoor use and FM. It features a slim design that combines visual appeal with a high standard of reliability. The detector has a Microcontroller Unit (MCU) performing comprehensive self-diagnostic tests, and result analysis. The FW521 is intelligent, addressable, and takes one address on the signaling Line Circuit (SLC) of the fire alarm control panel.

ATTENTION

Products must be installed per the National Fire Alarm Code, NFPA 72, CAN / ULC-S524, and/or National Electrical Code, depending on the country of the installation. Check the information on equipment used in the system from other manufacturers for instructions and restrictions. The detector should never be installed in the following places: where there is a lot of exhaust gas, kitchens, near fireplaces, boilers, etc. Smoke detectors should not be used with detector guards unless the suit has been evaluated and approved for this case.

NOTE

Do not paint this unit.

Any material extrapolated from this document or Maple Armor's instructions or other materials describing the product for promotional or advertising purposes, or any other purpose, including the description of the application, the use, installation, and testing of the product is the sole responsibility of the user. Maple Armor assumes no responsibility for the use. In no event shall Maple Armor's liability exceed the purchase price of the product.

INSTALLATION AND WIRING

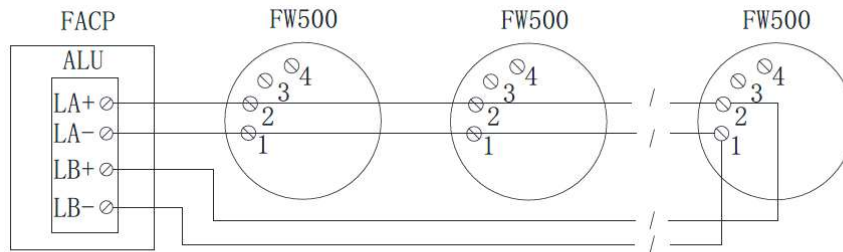
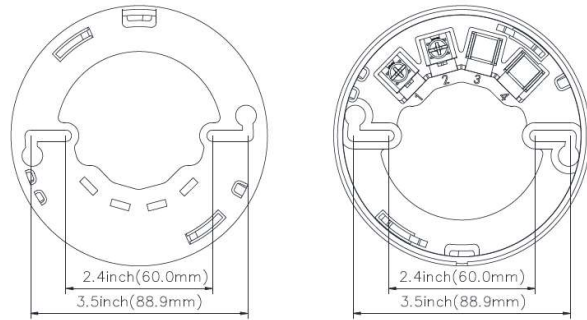
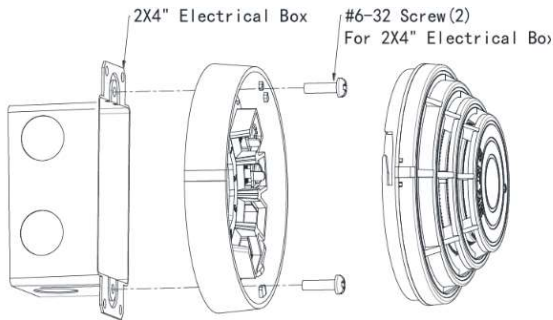

(a) Class A Circuit

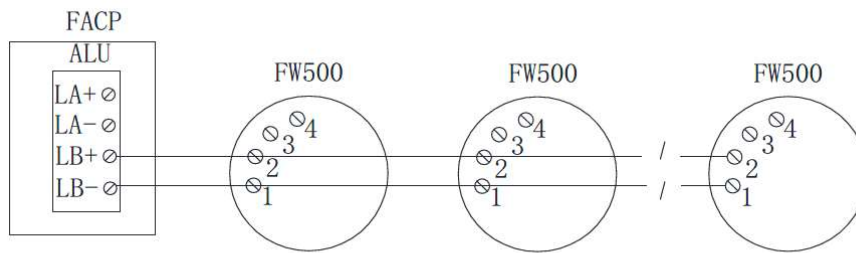

(b) Class B Circuit

SPECIFICATION

FW521	
Nominal Voltage	24 VDC
Voltage Range	17.6 to 28 VDC
Standby Current	0.1 mA
Alarm Current	1 mA
Fixed Temperature Rating	135°F (57.5°C)
Rate-of-Rise Detection	15°F/min. (8.3°C/min.)
Operating Temperature	32°F à 100°F (0°C à 38°C)
Operating Humidity	0% to 93% RH
Diameter	4.13 in. (105mm)
Height (with base)	1.87 in. (47.5mm)
Weight (with base)	4.3 oz (121g)
Mounting	Bases FW500/FW501
Mounting Orientation	Ceiling only
Distance between detectors	50 FT (15m).

CATALOG NUMBER TO ORDER

Model	Description
FW521	Heat detector
FW500	Heat detector base 4,13 in. (105mm)
FW501	Heat detector base 5,91 in. (150mm)