

Abort Switch

FW2732



The product must be used within its published specifications and properly installed, operated, and maintained, in accordance with these instructions. Not following these instructions may result in no alarm or false alarm. Maple Armor is not responsible for devices that are improperly installed, maintained or tested.

NOTE

Do not paint this device.

Any material extrapolated from this document or from Maple Armor's instructions or other documents describing the product for use in promotional or advertising claims, or for any other use, including description of the product's application, operation, installation, and testing is the sole responsibility of the user. Maple Armor will not assume any liability for such use. In no case will Maple Armor's liability exceed the purchase price paid for a product.

DESCRIPTION

The FW2732 Abort Switch is UL listed devices according to UL 38 and ULC-S528 for Fire Protective Signaling Systems for indoor use. The Abort Switch is designed for use with Fire Alarm Control Panel that include agent release capability and constructed using durable materials and solid components to ensure long-lasting performance.

Model FW2732 is a single action Abort Switch. When the releasing zone enters the alert or pre-discharge state, pressing and holding the abort switch will cancel the sequence for releasing the agent. The LED flashes once every 4 seconds in normal standby condition, and turn steady on when press.

For more detailed information on the releasing operation, please refer to the installation and operation manual of the FW2107 Fire Alarm Control Panel Agent Release Panel.

ATTENTION



The products must be installed in accordance with the National Electrical Code NFPA 70, the National Fire Alarm and Signaling Code NFPA 72, the Canadian codes CAN/ULC-S524 (Installation of Fire Alarm Systems), and CSA C22.1 Sec. 32 (Canadian Electrical Code), local codes, and the Local Authorities Having Jurisdiction. Prior to installing bases, make sure the product will have sufficient margin and wiring room. Do not over tighten the mounting screws to avoid base deformation, which may affect the device efficiency. Check information of equipment used in the system by other manufacturers for any guidelines or restrictions.

SPECIFICATION

Nominal Voltage	24VDC
Voltage Range	13 to 28VDC
Standby Current	150 uA
Alert Current	270uA
Alarm Current	270 uA
Operating Temperature	32°F to 120°F (0°C to 49°C)
Operating Humidity	0% to 93% RH
Dimension (with base)	98.5 mm (L) x 133.5 mm (W) x 32 mm (H)
Weight (with base)	7.4 oz (210 g)
Wiring Gauge	12 to 18 AWG
Compatible FACP	FW2107

INSTALLATION

1. Set the address (1-252) using the hand-held programmer model FW2412.
2. Mount the FW2701 surface mounting box onto a 2X4" electrical box, as illustrated in Figure 1.

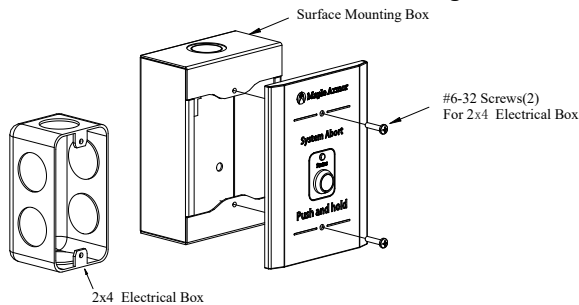
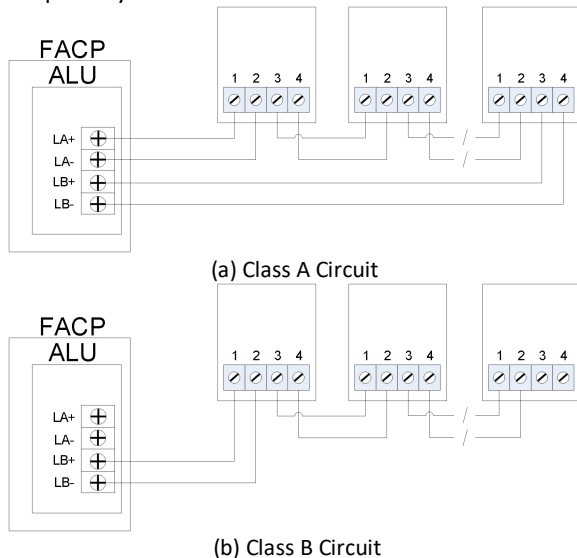

Figure 1. Abort Switch Installation

3. Connect the wires, see Figure 2. SLC wires are polarity insensitive.



(b) Class B Circuit
 Figure 2. Wiring Diagram

4. Combine the abort switch to the FW2701 surface mounting box using screws provided.
5. Apply power to the control unit to activate the SLC.

TESTING

1. Before testing, inform the proper authorities that the system is undergoing maintenance and will temporarily be put out of service.
2. Disable the system to prevent unwanted alarms.
3. Make sure the indicator LED on the device's surface is flashing. Failure to flash indicates a non-functioning device or a faulty wiring. Check the wiring and remount the device.
4. Activate a fire alarm signal. The LED should turn to steady lighting as specified in DESCRIPTION section.
5. Use the Allen Key provided to reset the switch from the top of the station.
6. Once the testing is completed, set the system back to normal operation and inform proper authorities.

MAINTENANCE

Return the device for reparation if it fails to flash or alarm during testing. Do not disassemble the device without permission.